



Dr. Tekill & Mr. Hyde®

THE EXHAUST



HARLEY-DAVIDSON

PRODUCT CATALOG



Model: **Fat Bob 114**
Body: **Jekill Bomb Black**
Header Set: **V-Strike Even Black**
End Cap: **3,5" Slashcut Black**

Dr. Jekyll & Mr. Hyde®

**ADJUST
YOUR
SOUND
TO THE
MOMENT**

THE EXHAUST



DR. JEKILL & MR. HYDE THE EXHAUST

— Dr. Jekill & Mr. Hyde gives motorcyclists the ultimate riding experience with The Exhaust. Our adjustable exhaust systems give you the possibility to adjust your sound to the moment and offer street legality, excellent performance, premium quality and 4 years warranty.

Our exhaust systems embody three distinct sound modes: the Dr. Jekill mode, the Dynamic mode and the Mr. Hyde mode. By a simple push of a button a valve inside the muffler closes, opens or opens halfway, which gives you the possibility to easily adjust your sound on the fly.

Dr. Jekill & Mr. Hyde | The Exhaust is a completely legal exhaust system that complies with European laws and is ECE, EG-BE and TÜV approved. Our exhaust systems are fully compliant with the latest Euro norm. The Exhaust is a result of German engineering and Dutch craftsmanship. By riders, for riders. With state of the art technology, perfectly crafted by the best engineers in town, we've created a tailor made exhaust for each and every bike.

Grab the attention of everybody in the street with Dr. Jekill & Mr. Hyde | The Exhaust. With a perfect sound, design and performance it completes your motorcycle.

Model: **CVO Road Glide**
Body: **Touring Black**
End Cap: **4,0" Big Shot Black**



THE BENEFITS

Model: **Street Bob 114**
Body: **Shorty Black**
Header Set: **V-Strike Even Black**
End Cap: **3,5" Streetfighter Aluminium**



DR. JEKILL & MR. HYDE THE BENEFITS

— The Jekill and Hyde Company gives motorcyclists the ultimate riding experience with The Exhaust: an electronically adjustable exhaust system which makes it possible to choose between three different modes on the fly. An exhaust second to none in regards to sound, esthetics and performance.

THREE SOUND MODES

Our exhaust systems embody three distinct personalities: the Dr. Jekill mode, the Dynamic mode and the Mr. Hyde mode. By a simple push of a button a valve inside the muffler closes, opens, or opens halfway, adjusting the sound of your exhaust.

STREET LEGAL

Dr. Jekill & Mr. Hyde | The Exhaust is a completely street legal system and complies with European legislation and laws. Our software is programmed to intervene subtly and almost imperceptibly when the parameters set by the legislation are reached. This ensures that you are 100% legal in all sound modes.

EXCELLENT PERFORMANCE

The Exhaust offers the best power and performance for your motorcycle. With a closed valve the exhaust performs like a stock exhaust, but when the valve opens, the rumbling sound is accompanied with an increase in power. When the valve is closing again, this happens so smooth that it is hardly noticeable while riding. This ensures a safe riding experience, regardless of which mode you are riding in.

PREMIUM QUALITY

Quality is one of our most important core values. Dr. Jekill & Mr. Hyde | The Exhaust does not only look and sound great, but it is also a reliable and high quality product. Only the best materials are used for the production which are all sourced from trusted suppliers in Europe.

4 YEAR WARRANTY

At The Jekill and Hyde Company we take pride in the quality and durability of our products. Our exhausts are made to last, designed and manufactured with longevity in mind. Therefore we deliver all new exhaust systems with a standard 4 year warranty.

THREE SOUND MODES



— Dr. Jekyll & Mr. Hyde | The Exhaust is a smart exhaust system that gives you the ultimate riding experience. Our electronically adjustable system allows riders to control the exhaust with a push of the button mounted on the handlebar. You can choose per situation whether you

want to ride in the Dr. Jekyll mode, the Dynamic mode or the Mr. Hyde mode. Be silent and become one with your surroundings when it is appropriate or make yourself heard when you want to. You decide.

Thanks to our intelligent software, the valve is always correctly positioned, making sure that you are 100% legal in all modes.



PUSH 1X FOR DR. JEKILL MODE

Dr. Jekyll Mode. The Valve is closed. The Dr. Jekyll mode is designed to blend in with your environment and become one with your surroundings. Perfect for long journeys and travelling through crowded areas.



PUSH 1X FOR MR. HYDE MODE

Mr. Hyde Mode. The valve is open. When your surroundings allow it, you can unleash Mr. Hyde and give your bike maximum sound. Feel the power of your bike and set free your inner beast. Experience a rumbling sensation that no stock exhaust can offer you.



PUSH 2X FOR DYNAMIC MODE

Dynamic Mode. The valve is half-way opened. The mode in between Dr. Jekyll and Mr. Hyde.



STREET LEGAL



Model: **Sportster Forty-Eight**
Body: **Shorty Black**
Header Set: **V-Strike Even Black**
End Cap: **3,5" Slashcut Black**



STREET LEGAL



— Our products have a EU type approval and are thus 100% street legal. To make this possible, our engineers have created the Smartbox. This electronic control unit, included with our exhaust systems, has the ability to read CAN bus signals coming from the motorcycle's ECU. The software within this unit is programmed to intervene subtly and almost imperceptibly when the parameters set by the legislation are reached. This ensures that you are 100% legal in all sound modes and never end up on the wrong side of the law, no matter what mode you select.

To be 100% street legal, our systems also have to be compliant with the current emission standards. We care deeply about the environment, that is why all of our exhaust systems are compliant with the latest Euro-norm. But do not just take our word for it, ask the proper authorities. Before we introduce a new exhaust system it gets thoroughly tested by them and only when they approve it, a Dr. Jekyll & Mr. Hyde exhaust system becomes available for your bike.

EXCELLENT PERFORMANCE



Model: **Low Rider S 114**
Body: **Twenty-One Brushed Stainless Steel**
Header Set: **21 Minimal Brushed**
End Cap: **4,7" Slashcut Bronze**

“THE LOW AND BASSY SOUNDS COMING OUT OF THE EXHAUST ARE **MUSIC TO MY EARS** AND CRUCIAL FOR MY RIDING STYLE!. I REALLY LIKE IT.
CHRIS PFEIFFER



Model: **Fat Bob 114**
Body: **Twenty-One Brushed Stainless Steel**
Header Set: **21 Minimal Brushed**
End Cap: **4,7" Slashcut Black**

EXCELLENT PERFORMANCE

— When unleashing Mr. Hyde you will feel an increase of power within your bike. Opening the valve gives your bike more performance and you will experience a sensation that no stock exhaust can give.

When, because of legality reasons, the system interferes and closes the valve for a moment, this is done so smoothly that you will barely notice this in the performance of your bike; making sure you always have a safe journey.

PREMIUM QUALITY



Model: **Sport Glide 107**
Body: **The One Black**
End Cap: **4,0" Big Shot Chrome**



PREMIUM QUALITY

— Quality is one of our most important core values. Dr. Jekyll & Mr. Hyde | The Exhaust does not only look and sound great, it also needs to be a reliable and high quality product. Because of our years of experience and expertise, we keep on perfecting our products, making sure that the customer always rides with a state of the art and perfectly crafted exhaust system. To achieve this, all our exhaust systems need to withstand all kinds

of extreme (weather)conditions and extreme heat. Therefore they are thoroughly tested, before going into production. When all the tests are passed and an exhaust becomes available to the public, only the highest quality materials are used for the production which are all sourced from trusted suppliers in Europe.

4 YEAR WARRANTY

— We want you to ride with peace of mind. Not only when it comes to legality, but also when you should encounter a problem with your Dr. Jekyll & Mr. Hyde system. That is why we deliver every exhaust with a standard 4 year warranty.*

** To have an exact overview of the Dr. Jekyll & Mr. Hyde warranty terms, we invite you to read the warranty terms carefully at: jekyllandhyde.com/en/warranty*



Model: **Low Rider S 114**
Body: **Twenty-One Black**
Header Set: **21 Full Black**
End Cap: **4,7" Slashcut Black**

4 YEAR WARRANTY



HOW IT WORKS

Model: **CVO Road Glide**
Body: **Touring Black**
End Cap: **CVO End Cap Adapter Red**



HOW IT WORKS

— When riding with Dr. Jekyll & Mr. Hyde you feel the raw power of your bike and still have a carefree ride since you always remain within the limits of the law. The Exhaust consists of several (electronic) parts that all contribute to the ultimate riding experience.

01 MODESWITCH

Push it to control your exhaust system and choose your sound mode. Looks and function may vary per country.

02 SMARTBOX

Intelligent software unit that controls the servomotors.

03 SERVOMOTORS

These will react to the signal of the Smartbox and position the valve in the required mode.

04 THE EXHAUST

Reacting to the servomotors our patented valve system will be positioned in the required mode.

A LOOK INSIDE

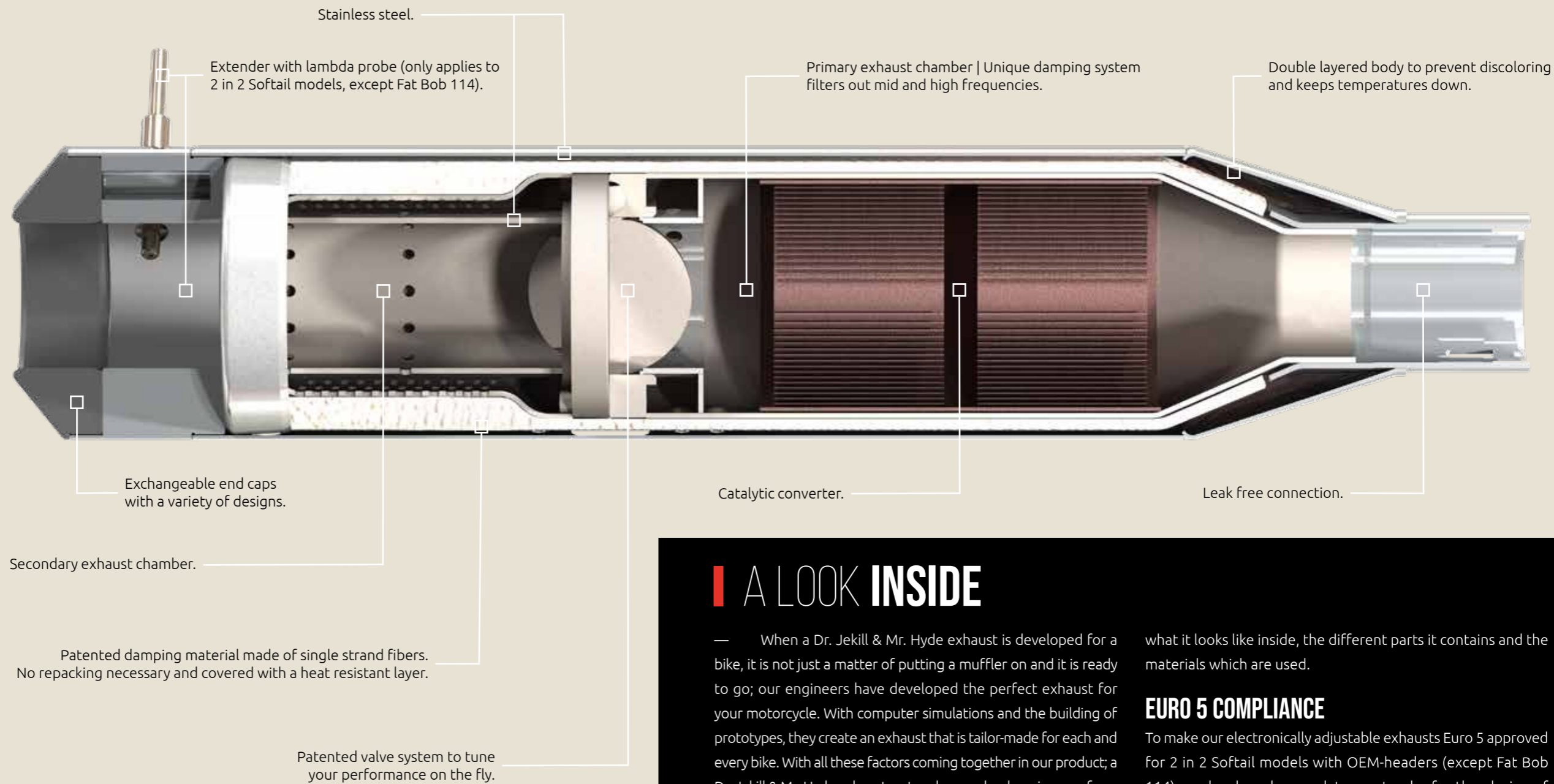

A LOOK INSIDE

— When a Dr. Jekyll & Mr. Hyde exhaust is developed for a bike, it is not just a matter of putting a muffler on and it is ready to go; our engineers have developed the perfect exhaust for your motorcycle. With computer simulations and the building of prototypes, they create an exhaust that is tailor-made for each and every bike. With all these factors coming together in our product; a Dr. Jekyll & Mr. Hyde exhaust system has made a long journey from the drawing board to the finished product called The Exhaust.

Take a look at the cross section of The Exhaust above to see

what it looks like inside, the different parts it contains and the materials which are used.

EURO 5 COMPLIANCE

To make our electronically adjustable exhausts Euro 5 approved for 2 in 2 Softtail models with OEM-headers (except Fat Bob 114) we developed a mandatory extender for the placing of the lambda probe. This extender is placed between the body and the end cap. This solution is an important upgrade which guarantees Euro 5 compliance.

* Cross section may differ per exhaust type.

HOW IT SOUNDS

PUSH THE BUTTON

1X PUSH 1X FOR
DR. JEKILL MODE

1X PUSH 1X FOR
MR. HYDE MODE

2X PUSH 2X FOR
DYNAMIC MODE

GO FOR BETTER SOUND

— When you ride in Mr. Hyde mode, the valve opens and you enjoy a deep rumbling sound that has been specially developed for your motorcycle. As a company we find it necessary that this sound is not 'loud and annoying'. Our specialized (sound) engineers have crafted a tailor-made sound for every bike that on the one hand gives riders the ultimate riding experience, but on the other hand is not a nuisance to others.

Your riding experience is accompanied with a deep bass sound without any treble or mid tones. It enhances the already characteristic sound from the Harley-Davidson® engine and takes this to a whole new level. Dr. Jekill & Mr. Hyde | The Exhaust provides you with a complete product that combines the best elements of performance, design and sound quality.



CONFIGURATOR



Model: **Fat Boy 114**
Body: **Shorty Satin Chrome**
Header Set: **V-Strike Even Satin Chrome**
End Cap: **3,5" Big Shot Chrome**



CONFIGURE YOURS

COMPANY WEBSITE

— The Dr. Jekyll & Mr. Hyde website is fully developed and designed with the rider in mind. Pick a motorcycle brand of choice and start your personal route to the perfect Dr. Jekyll & Mr. Hyde exhaust. And while you're at it, get inspired by our blogs and road stories or check out the coolest pictures and videos to boost your own creativity.

Visit our company website at: jekillandhyde.com

EXHAUST CONFIGURATOR

— Customize your own Exhaust for Harley-Davidson® in our Exhaust Configurator: your perfect exhaust is only a few clicks away. Pick your body colour, end caps and electronics and make it yours. Let's build something beautiful.

CONFIGURATION CODE

— As of now it is possible to generate a configuration code while configuring a Dr. Jekyll & Mr. Hyde exhaust. If you download or email a PDF, or directly requests a quote, a configuration code will be added to the attached PDF automatically. Show or email this unique code to your dealer and he or she will be able to get your desired exhaust configuration instantly. Simple as that!

Check: configurator.jekillandhyde.com for latest product / model updates.

YOUR CHOICE

COLOUR / MATERIALS*















* Numbers indicate available colour / material options.

⚠ Not compatible for Euro 5 models in combination with OEM headers.

Check: configurator.jekillandhyde.com for latest product / model updates.

BODIES

 THE ONE ^{1,2}	 TWENTY-ONE ^{2,5}
 SHORTY ^{1,2,3}	 FAT BOB ^{1,2}
 SHORTY EURO 5 (OEM HEADER ONLY) ^{1,2,3}	 V-ROD ^{1,2}
 JEKILL BOMB ^{1,2}	 NRS ^{1,2}
 TOURING ^{1,2}	 MUSCLE ^{2,3}
 FAT BOMB ^{1,2,3}	 DEMON ^{2,8}



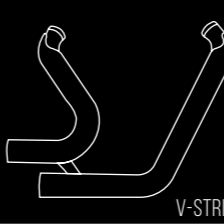
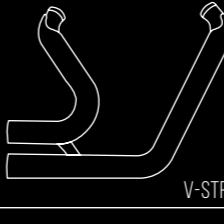
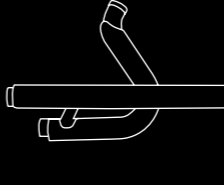

END CAPS

 BIG SHOT ^{1,2,7}
 STREETFIGHTER ^{2,4,6,7}
 TAPERED ^{1,2}
 VINTAGE ^{2,4}
 SLASHCUT ^{1,2,7}
 DEMON SLASHCUT ⁹
 TWENTY-ONE SLASHCUT ^{2,6,7}

HEADER SETS

 V-STRIKE UNEVEN ^{1,2}
 V-STRIKE EVEN ^{1,2,3}
 OLD STYLE ^{1,2}

MODESWITCH

 CLUTCH ^{1,2}	
 CLASSIC ²	
EXTRAS	
 EXTENDERS ²	
 FISHTAIL ADAPTERS	
 CVO END CAP ADAPTERS ^{1,2,10}	

END CAPS

Give your exhaust the final touch with a set of Dr. Jekill & Mr. Hyde end caps. Let it fit in with the design or let it stand out, it's your choice.

HEADER SETS

We offer several header sets to complete the look of your bike.

MODESWITCHES

Depending on your motorcycle, you have the choice between the Classic or Clutch Modeswitch, where the latter integrates into the line of your original clutch clamp.

EXTRAS

For several models we offer optional extenders. These extenders add another 33mm to your entire exhaust. You can also add a special fishtail adapter which enables you to mount an original Harley-Davidson® fishtail end cap to your Dr. Jekill & Mr. Hyde exhaust.

CVO END CAP ADAPTERS

An adapter that makes it possible to mount the original Harley-Davidson® CVO end caps on the Dr. Jekill & Mr. Hyde exhaust system.

— As a rider you want to have an exhaust that suits the look of your bike and also complies with your personal taste. We offer a wide array of exhaust systems tailor-made for various Harley-Davidson® models.

BODIES

In the scheme above, you can see an overview of our bodies and the colours in which they are available. To see which body is available for your motorcycle, we invite you to check out our online configurator.



TAILOR-MADE EXHAUST SYSTEMS

END CAPS



DIFFERENT LOOK? **CHANGE YOUR END CAPS**

— Every now and then it is time for a different look. Therefore we give you the choice between different sets of end caps. When you decide it's time for a new look, contact your dealer and change your end caps. It completely changes the appearance of your exhaust and motorcycle. For inspiration visit our social pages.

For more info about all available end caps visit:
jekillandhyde.com/en/accessories



HEADER SETS

Model: **Low Rider S 114**
Body: **Shorty Black**
Header Set: **V-Strike Even Black**
End Cap: **3,5" Streetfighter Black**



STRIVING FOR PERFECTION? CHANGE YOUR HEADERS

— To add that extra special look to your bike, we offer various header sets to complete your motorcycle.

V-STRIKE

Our most popular header set. The V-Strike offers you a better ground clearance, a compact look with a visible rear wheel and an even better sound.

OLD STYLE

You prefer it old school? Why not equip your bike with an Old Style header combined with Jekill Bomb bodies. Perfect for the rider that likes a vintage look combined with modern technology.

Check online if your preferred header set is available for your motorcycle at configurator.jekillandhyde.com



MODELS

Model: **Breakout 114**
Body: **Shorty Black**
End Cap: **3,5" Big Shot Black**



Model: **Road Glide 114**
Body: **Touring Black**
End Cap: **4,0" Big Shot Chrome**



Model: **FXDR 114**
Body: **Demon Black**
End Cap: **Demon Slashcut Carbon Fibre**



HARLEY-DAVIDSON® AND DR. JEKILL & MR. HYDE | THE EXHAUST **THE PERFECT FIT**

— At The Jekill and Hyde Company we try to create the widest possible range of exhaust systems for the Harley-Davidson® rider. That is why we offer systems for almost every Harley-Davidson® family and have systems available for models that go back as far as 1984. Check out our configurator at configurator.jekillandhyde.com to see all our available options for Harley-Davidson® models.

CLEANING KIT



CLEANING KIT

— At The Jekill and Hyde Company we are always looking for something extra to give our customers in addition to the ultimate adjustable exhaust. It is common knowledge that most motorcyclists clean their motorcycles with, at least, the same attention as riding it. Therefore the idea of a cleaning kit was a logical addition.

Of course it is very important that this set has to be of the same premium quality as the exhaust. Together with Motul we

started a cooperation to release a cleaning kit that would make your exhaust (and the rest of your bike) shine like never before.

CONTENTS OF THE CLEANING KIT

The Motul cleaning kit consists of the cleaning product, two microfiber cloths and a surprise giveaway. Of course it all comes in a package that is completely in Dr. Jekill & Mr. Hyde style.



EC-CARD

EC-CARD

— Dr. Jekill & Mr. Hyde exhaust systems are completely legal and approved by all authorities. To prove the legality of the system in any given situation you can refer to the approval numbers and the serial number on the type shield on the exhaust.

EC-CARD WITH QR-CODE

Next to that you get an EC-card with your system, where you will find the specific registration numbers for your model as well

as the serial number of your exhaust system. Furthermore the card has a QR-code that you can scan with your smartphone. After scanning the code all the inspection papers corresponding with your exhaust appear on your screen. Proving once and for all the Dr. Jekill & Mr. Hyde exhaust is fully compliant with the law and legislation.

OUR MISSION



OUR MISSION

— With everything we do, we want to give the ultimate riding experience. We achieve this by giving the possibility to adjust your sound to the moment and offering street legality, excellent performance and premium quality.

We want to pursue our mission and vision by maintaining and extending our world leading position in developing, manufacturing and supplying the best adjustable exhaust systems for motorcycles, always exceeding customer service expectations.



Dr. Jekyll & Mr. Hyde[®]

THE EXHAUST

YOU ARE DR. JEKILL & MR. HYDE
SHARE #MYJEKILLANDHYDE

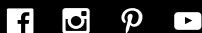

#JEKILLANDHYDE #DRJEKILLANDMRHYDE #THEEXHAUST

Your Local Dealer

JEKILLANDHYDE.COM

